

All-in-one Residential ESS

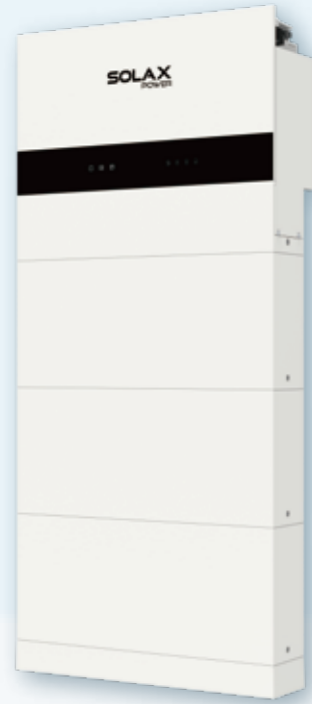

X1-IES

2.5kW / 3.0kW / 3.7kW / 5.0kW /
6.0kW / 8.0kW

Efficiency Curve

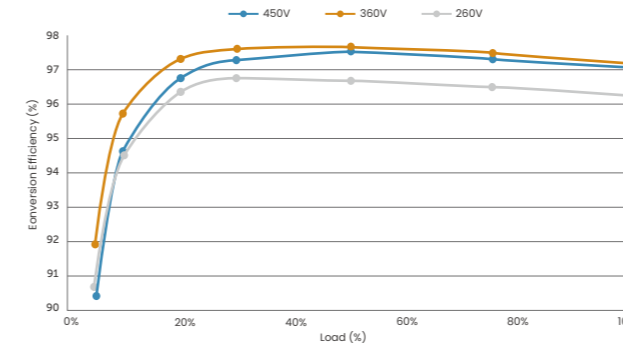

Circuit Diagram

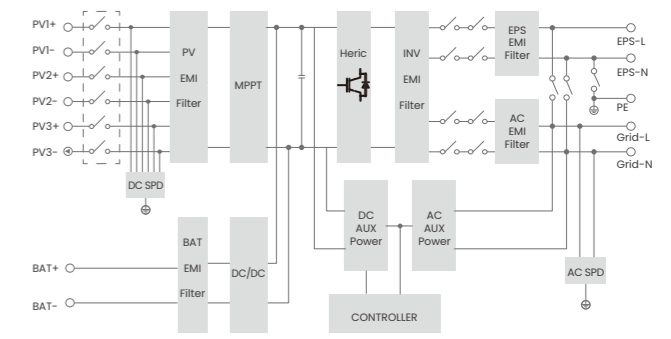

SYSTEM OVERVIEW



Smart Management

- AI ready, forecasting solar generation and home consumption for smart energy management strategy control*
- VPP ready with a variety of compatibility(OpenADR, IEEE2030.5, FCAS, API)**
- Smart loads management (e.g., heat pump, smart EV charger)
- Micro-grid support for real-time grid/off-grid balancing
- Wireless meter compatibility
- Global MPP scan for optimal energy harvest

Assured Reliability

- IP66 protection degree
- Type II SPD on AC&DC side
- AFCI protection (optional)
- UPS-level switchover time <10ms

High Performance

- Max. 50A charge/discharge current
- 200% oversizing and 200% PV input power
- Up to 200% EPS output for 10s
- Low start-up voltage for longer operation
- Cycle life > 6000 times

Flexible Adaptability

- All-in-one, plug-and-play design
- Max. 20A DC input current for high power solar panel

*Additional Datahub1000 required
**Feature to be upgraded in the future

Rated output power	2.5 / 3.0 / 3.7 / 5.0 / 6.0 / 8.0 kW			
Number of batteries	1	2	3	4
Nominal capacity ^①	5.1 kWh	10.2 kWh	15.3 kWh	20.4 kWh
Usable energy ^②	4.6 kWh	9.2 kWh	13.8 kWh	18.4 kWh
Max. charge / discharge power ^③	5.1 kW	8.0 kW	8.0 kW	8.0 kW
Degree of protection	IP66			
Operating temperature range	-30 ~ 53°C			
Allowable relative humidity range	5 ~ 95% (No condensation)			
Max. operating altitude	3000 m			
Net weight ^④	87.2 kg	134.2 kg	181.2 kg	134.2 kg / 99.2 kg
Dimension (W x H x D)	730 x 908 x 210 mm	730 x 1226 x 210 mm	730 x 1544 x 210 mm	730 x 1226 x 210 mm / 730 x 809 x 150 mm
Display	LCD			
Cooling concept	Natural cooling			
Topology	Non-isolated			
Communication	RS485, Pocket-X, CAN, DO, DI			

① Test conditions: 25°C, 100% depth of discharge (DoD), 0.2C charge & discharge
 ② System usable energy may vary with inverter different setting
 ③ The max.charge/discharge power must not exceed the rated output power (the table takes the maximum power inverter as an example)
 ④ Different inverter models have different weights. The heaviest one is taken as an example

	X1-IES-2.5K	X1-IES-3K	X1-IES-3.7K	X1-IES-5K	X1-IES-6K	X1-IES-8K
PV INPUT						
Max. recommended PV array power	5.0 kWp	6.0 kWp	7.4 kWp	10.0 kWp	12.0 kWp	16.0 kWp
Max. PV input voltage ^①	600 V					
Nominal PV input voltage	360 V					
MPPT voltage range ^②	40 ~ 560 V					
Start-up voltage	50 V					
No. of MPP trackers / Strings per MPP tracker	2 / (1 / 1)			3 / (1 / 1 / 1)		
Max. input current per MPPT (MPPT1/2/3)	20 A / 20 A			20 A / 20 A / 20 A		
Max. input short circuit current per MPPT (MPPT1/2/3)	30A / 30A			30A / 30A / 30 A		
AC INPUT & OUTPUT (ON-GRID)						
Rated output power	2500 W	3000 W	3680 W	5000 W (4600 for VDE4105, 4999 for AS4777)	6000 W	8000 W
Rated output current	10.9 A	13.1 A	16.0 A	21.8 A	26.1 A	34.8 A
Max. output apparent power	2500 VA	3300 VA	3680 VA	5000 VA (4600 for VDE4105, 4999 for AS4777, 5000 for C10/11)	6600 VA	8000 VA
Max. output continuous current	10.9 A	14.4 A	16.0 A	21.8 A	28.7 A	34.8 A
Nominal AC voltage	1 / N / PE, 220 / 230 / 240 V					
Max. AC input apparent power	6300 VA	6300 VA	7360 VA	9200 VA	9200 VA	9200 VA
Max. AC input current	27.4 A	27.4 A	32.0 A	40.0 A	40.0 A	40.0 A
Nominal AC frequency	50 Hz / 60 Hz					
AC frequency range ^③	50 ± 5 Hz / 60 ± 5 Hz					
Adjustable Power Factor range	~ 1 (0.8 lagging to 0.8 leading)					
THDi (rated power)	< 3%					
BATTERY						
Battery voltage range	80 ~ 480 V					
Communication interfaces	CAN / RS485					
BMS module	TBMS-MCS0800E					
Battery module	TP-HS50E					
Composition	TBMS-MCS0800E + TP-HS50E × n + Base Dimensions + Series Box (Required for two columns)					
Battery type	Li-ion (LFP)					
Nominal capacity / Nominal capacity ^④	5.1 kWh / 50 Ah					
Usable energy ^⑤	4.6 kWh					
Standard power	3 kW					
Max power	5.1 kW					
Max. charge / discharge current ^⑥	50 A					
Cycle life	> 6000 cycles					
Warranty	10 years					
Safety	CE, RCM, TUV (IEC62619), RoHS, REACH					
TBMS-MCS0800E dimensions (W × H × D) / Weight	730 × 165 × 150 mm / 9.3 kg					
TP-HS50E dimensions (W × H × D) / Weight	730 × 318 × 150 mm / 47 kg					
Base dimensions (W × H × D) / Weight	730 × 75 × 150 mm / 3.9 kg					

	X1-IES-2.5K	X1-IES-3K	X1-IES-3.7K	X1-IES-5K	X1-IES-6K	X1-IES-8K
BATTERY						
Series box dimensions (W × H × D) / Weight	167 × 91.5 × 121 mm/ 1.3 kg					
EPS (OFF-GRID) OUTPUT (WITH BATTERY)						
Rated EPS output voltage, frequency	220 V, 230 V, 240 V, 50 Hz / 60 Hz					
Rated EPS output power	2500 VA	3000 VA	3680 VA	5000 VA	6000 VA	8000 VA
Peak EPS output power	2 times of rated power, 10 s					
Switchover time	< 10 ms					
EFFICIENCY						
Max. efficiency	97.6%					
European efficiency	97.0%					
ENVIRONMENT LIMIT						
Ingress protection	IP66					
Operating ambient temperature range ^⑦	-35 ~ 60°C (derating at 45°C)					
Max. operating altitude	3000 m					
Relative humidity	0 ~ 100% RH (condensing)					
GENERAL						
Dimensions (W × H × D)	717 × 350 × 210 mm					
Net weight	26.2 kg			26.4 kg		
Cooling concept	Nature cooling					
Communication interfaces	RS485, Pocket-X, CAN, DO, DI					
Power consumption (night)	< 40 W for hot standby, < 5 W for cold standby					
Topology	Non-isolated					
Certificates and approvals	IEC62109-1 / IEC62109-2, VDE 0126-1-1 A1:2012 / VDE-AR-N 4105 / G98 / G99 / AS4777 / EN50549 / CEI 0-21					
PROTECTION						
Protections	Over voltage protection, DC reverse-polarity protection, Residual current detection, Over temperature protection					
Active anti-islanding method	Frequency shift					
Surge protection (DC / AC)	DC: Type II, AC: Type II					

① The maximum input voltage is the upper limit of the DC voltage. Any higher input DC voltage would probably damage the inverter
 ② Input voltage exceeding the MPPT voltage range may trigger inverter protection
 ③ The AC frequency range may vary from different country codes
 ④ Test conditions: 25°C, 100% depth of discharge (DoD), 0.2C charge & discharge
 ⑤ System usable energy may vary with inverter different settings
 ⑥ Discharge: In case of the battery cell's temperature range of -20°C~10°C and 45°C~53°C, the discharge current will be reduced; Charge: In case of the battery cell's temperature range of 0°C~25°C and 45°C~53°C, the charge current will be reduced. Product charge or discharge power depends on the actual temperature of the battery pack
 ⑦ Derating above +45°C

All-in-one Residential ESS

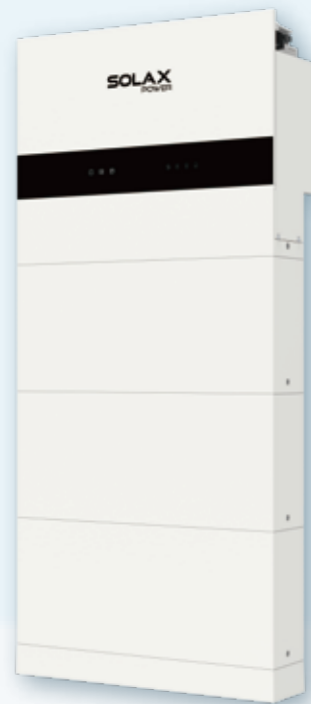

X3-IES

4kW / 5kW / 6kW / 8kW / 10kW /
12kW / 15kW

Efficiency Curve

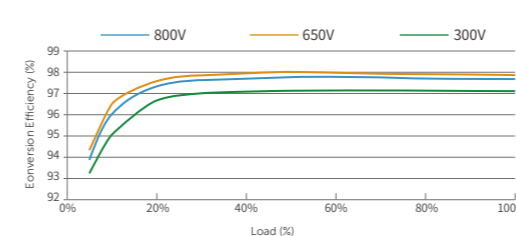

Circuit Diagram

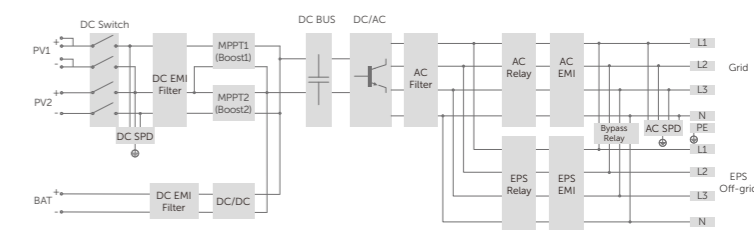

SYSTEM OVERVIEW

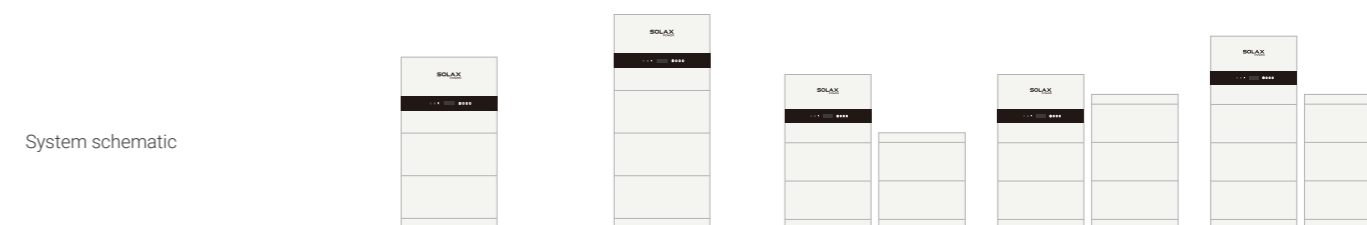

Rated output power	4 / 5 / 6 / 8 / 10 / 12 / 15 kW				
Number of batteries	2	3	4	5	6
Nominal capacity ^①	10.2 kWh	15.3 kWh	20.4 kWh	25.6 kWh	30.7 kWh
Usable energy ^②	9.2 kWh	13.8 kWh	18.4 kWh	23.0 kWh	27.6 kWh
Max. charge / discharge power ^③	10.2 kW	15.0 kW	15.0 kW	15.0 kW	15.0 kW
Degree of protection	IP66				
Operating temperature range	-30 ~ 53°C				
Allowable relative humidity range	5 ~ 95% (No condensation)				
Max. operating altitude	3000 m				
Net weight ^④	144.2 kg	191.2 kg	144.2 kg / 100.5 kg	144.2 kg / 147.5 kg	191.2 kg / 147.5 kg
Dimension (W x H x D)	730 x 1281 x 209.5 mm	730 x 1599 x 209.5 mm	730 x 1281 x 209.5 mm / 730 x 809 x 150 mm	730 x 1281 x 209.5 mm / 730 x 1127 x 150 mm	730 x 1599 x 209.5 mm / 730 x 1127 x 150 mm
Display	LCD				
Cooling concept	Natural cooling				
Topology	Non-isolated				
Communication	RS485, Pocket-X, USB, CAN, DO, DI				

Smart Management

- AI ready, forecasting solar generation and home consumption for smart energy management strategy control*
- VPP ready with a variety of compatibility(OpenADR, IEEE2030.5, FCAS, API)**
- Smart loads management (e.g., heat pump, smart EV charger)
- Micro-grid support for real-time grid/off-grid balancing
- Wireless meter compatibility
- Global MPP scan for optimal energy harvest

Assured Reliability

- IP66 protection degree
- Type II SPD on AC&DC side
- AFCI protection (optional)
- Up to 200% EPS output for 10s
- UPS-level switchover time <10ms

High Performance

- Max. 50A charge/discharge current
- 200% oversizing and 200% PV input power
- Low start-up voltage for longer operation
- Cycle life > 6000 times

Flexible Adaptability

- All-in-one, plug-and-play design
- Max. 20A DC input current for high power solar panel

*Additional Datahub1000 required
**Feature to be upgraded in the future

① Test conditions: 25°C, 100% depth of discharge (DoD), 0.2C charge & discharge
② System usable energy may vary with inverter different setting
③ The max.charge/discharge power must not exceed the rated output power (the table takes the maximum power inverter as an example)
④ Different inverter models have different weights. The heaviest one is taken as an example

	X3-IES-4K	X3-IES-5K	X3-IES-6K	X3-IES-8K	X3-IES-10K	X3-IES-12K	X3-IES-15K
PV INPUT							
Max. recommended PV array power	8 kWp	10 kWp	12 kWp	16 kWp	20 kWp	24 kWp	30 kWp
Max. PV input voltage ^①	1000 V						
Nominal PV input voltage	600 V						
Operating voltage range	90 ~ 950 V						
MPPT voltage range ^②	110 ~ 950 V						
Start-up voltage	140 V						
No. of MPP trackers / Strings per MPP tracker	2 / (1 / 1)			2 / (2 / 1)			
Max. input current per MPPT (MPPT1/2)	20 A / 20 A			32 A / 20 A			
Max. input short circuit current per MPPT (MPPT1/2)	25 A / 25 A			40 A / 25 A			
AC INPUT & OUTPUT (ON-GRID)							
Rated output power	4000 W	5000 W	6000 W	8000 W	10000 W (AS4777 9999)	12000 W	15000 W
Rated output current	5.8 A	7.3 A	8.7 A	11.6 A	14.5 A	17.4 A	21.8 A
Max. output apparent power	4000 VA	5500 VA	6600 VA	8800 VA	10000 VA (AS4777 9999)	13200 VA	16500 VA
Max. output continuous current	5.8 A	8.0 A	9.6 A	12.8 A	14.5 A	19.2 A	24.0 A
Nominal AC voltage	3 / N / PE, 220 / 380 V 3 / N / PE, 230 / 400 V						
Max. AC input apparent power	10 kVA	10 kVA	12 kVA	16 kVA	20 kVA	20 kVA	20 kVA
Max. AC input current	16.1 A	16.1 A	19.3 A	25.8 A	32.0 A	32.0 A	32.0 A
Nominal AC frequency	50 Hz / 60 Hz						
AC frequency range ^③	50 ± 5 Hz / 60 ± 5 Hz						
Adjustable power factor range	~ 1 (0.8 lagging to 0.8 leading)						
THDi (rated power)	< 3%						
BATTERY							
Battery voltage range	160 ~ 800 V						
Communication interfaces	CAN / RS485						
BMS module	TBMS-MCS0800E						
Battery module	TP-HS50E						
Composition	TBMS-MCS0800E + TP-HS50E x n + Base Dimensions + Series Box (Required for two columns)						
Battery type	Li-ion (LFP)						
Nominal capacity / Nominal capacity ^④	5.1 kWh / 50 Ah						
Usable energy ^⑤	4.6 kWh						
Standard power	3 kW						
Max power	5.1 kW						
Max. charge / discharge current ^⑥	50 A						
Cycle life	> 6000 cycles						
Warranty	10 years						
Safety	CE, RCM, TUV (IEC62619), RoHS, REACH						
TBMS-MCS0800E dimensions (W x H x D) / Weight	730 x 165 x 150 mm / 9.3 kg						
TP-HS50E dimensions (W x H x D) / Weight	730 x 318 x 150 mm / 47 kg						
Base dimensions (W x H x D) / Weight	730 x 75 x 150 mm / 3.9 kg						
Series box dimensions (W x H x D) / Weight	167 x 91.5 x 121 mm / 1.3 kg						

	X3-IES-4K	X3-IES-5K	X3-IES-6K	X3-IES-8K	X3-IES-10K	X3-IES-12K	X3-IES-15K
EPS (OFF-GRID) OUTPUT (WITH BATTERY)							
Rated EPS output voltage, frequency	230 V / 400 V, 50 Hz / 60 Hz						
Rated EPS output power	4 kVA	5 kVA	6 kVA	8 kVA	10 kVA	12 kVA	15 kVA
Peak EPS output power	2 times of rated power, 10s						
Switchover time	< 10 ms						
EFFICIENCY							
Max. efficiency	98.0%						
European efficiency	97.7%						
ENVIRONMENT LIMIT							
Ingress protection	IP66						
Operating ambient temperature range ^⑦	-35 ~ 60°C (derating at 45°C)						
Max. operating altitude	3000 m						
Relative humidity	0 ~ 100% RH (condensing)						
Overvoltage Category	Mains: III, Battery: II, PV: II						
GENERAL							
Dimensions (W x H x D)	717 x 405 x 209.5 mm						
Net weight	37 kg						
Cooling concept	Nature cooling						
Communication interfaces	RS485, Pocket-X, CAN, DO, DI						
Power consumption (night)	< 40 W for hot standby, < 5 W for cold standby						
Topology	Non-isolated						
Certificates and approvals	IEC62109-1 / IEC62109-2, VDE 0126-1-1 A1:2012 / VDE-AR-N 4105 / G98 / G99 / AS4777 / EN50549 / CEI 0-21						
PROTECTION							
Protections	Over voltage protection, DC reverse-polarity protection, Residual current detection, Over temperature protection, DC isolation protection, Grid monitoring, DC injection monitoring, Back feed current monitoring						
Active anti-islanding method	Frequency shift						
Surge protection (DC / AC)	DC: Type II, AC: Type II						
Arc-fault circuit interrupter (AFCI)	Optional						

① The maximum input voltage is the upper limit of the DC voltage. Any higher input DC voltage would probably damage the inverter
 ② Input voltage exceeding the MPPT voltage range may trigger inverter protection
 ③ The AC frequency range may vary from different country codes
 ④ Test conditions: 25°C, 100% depth of discharge (DoD), 0.2C charge & discharge
 ⑤ System usable energy may vary with inverter different settings
 ⑥ Discharge: In case of the battery cell's temperature range of -20°C~10°C and 45°C~53 °C, the discharge current will be reduced; Charge: In case of the battery cell's temperature range of 0°C~25°C and 45°C~53°C, the charge current will be reduced. Product charge or discharge power depends on the actual temperature of the battery pack
 ⑦ Derating above +45°C

All-in-one Residential ESS

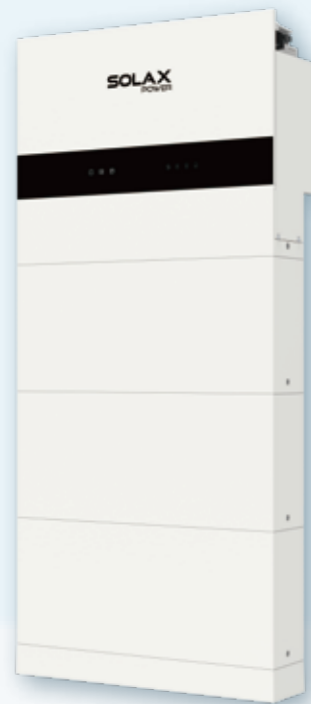

X3-IES-P

8kW / 10kW / 12kW / 15kW

Efficiency Curve

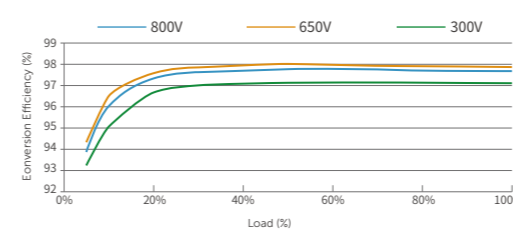

Circuit Diagram

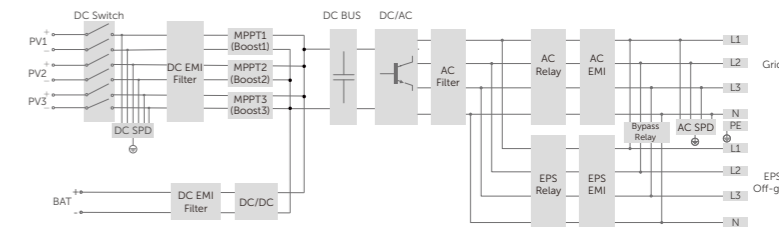

SYSTEM OVERVIEW

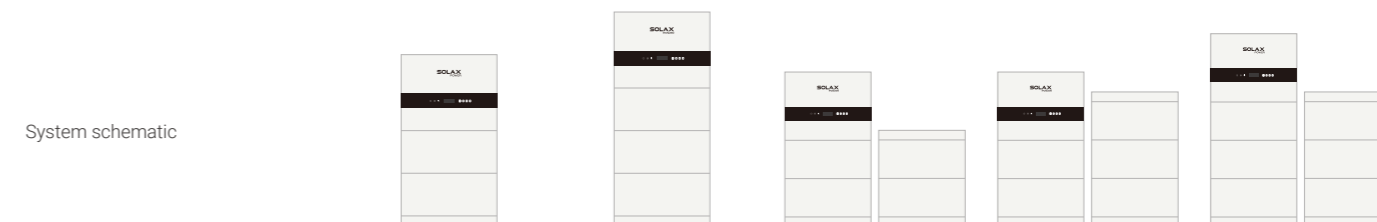

Rated output power	8 / 10 / 12 / 15 kW				
Number of batteries	2	3	4	5	6
Nominal capacity ^①	10.2 kWh	15.3 kWh	20.4 kWh	25.6 kWh	30.7 kWh
Usable energy ^②	9.2 kWh	13.8 kWh	18.4 kWh	23.0 kWh	27.6 kWh
Max. charge / discharge power ^③	10.2 kW	15.0 kW	15.0 kW	15.0 kW	15.0 kW
Degree of protection	IP66				
Operating temperature range	-30 ~ 53°C				
Allowable relative humidity range	5 ~ 95% (No condensation)				
Max. operating altitude	3000 m				
Net weight ^④	147.2 kg	194.2 kg	147.2 / 103.5 kg	147.2 / 150.5 kg	194.2 / 150.5 kg
Dimension (W x H x D)	730 x 1281 x 209.5 mm	730 x 1599 x 209.5 mm	730 x 1281 x 209.5 mm / 730 x 809 x 150 mm	730 x 1281 x 209.5 mm / 730 x 1127 x 150 mm	730 x 1599 x 209.5 mm / 730 x 1127 x 150 mm
Display	LCD				
Cooling concept	Natural cooling				
Topology	Non-isolated				
Communication	RS485, Pocket-X, USB, CAN, DO, DI				

Smart Management

- AI ready, forecasting solar generation and home consumption for smart energy management strategy control*
- VPP ready with a variety of compatibility (OpenADR, IEEE2030.5, FCAS, API)**
- Micro-grid support for real-time balance in grid/off-grid
- Wireless meter solution
- Smart Schedule, Smart Scene, and 7*24h TOU
- Global MPP scan for optimal energy harvest

High Performance

- Max. 3 MPPTs for versatile application scenarios
- 200% oversizing and 200% PV input power
- Max. 20A PV input per MPPT
- Low startup voltage for higher energy harvest

Assured Reliability

- IP66 protection degree
- Type II SPD on AC&DC side
- AFCI protection (optional)**
- Unique battery heating tech and wide temperature tolerance
- Up to 200% EPS output for 10s
- UPS-level switchover time <10ms

Flexible Adaptability

- All-in-one, plug-and-play design
- Support smart scene functions (e.g., heat pump, EV charger)
- Versatile installation for varied needs

*Additional Datahub1000 required
**Feature to be upgraded in the future

① Test conditions: 25°C, 100% depth of discharge (DoD), 0.2C charge & discharge
② System usable energy may vary with inverter different setting
③ The max.charge/discharge power must not exceed the rated output power (the table takes the maximum power inverter as an example)
④ Different inverter models have different weights. The heaviest one is taken as an example

	X3-IES-8K-P	X3-IES-10K-P	X3-IES-12K-P	X3-IES-15K-P
PV INPUT				
Max. recommended PV array power	16 kWp	20 kWp	24 kWp	30 kWp
Max. PV input voltage ^①	1000 V			
Nominal PV input voltage	600 V			
Operating voltage range	90 ~ 950 V			
MPPT voltage range ^②	110 ~ 950 V			
Start-up voltage	140 V			
No. of MPP trackers / Strings per MPP tracker	3 / (1 / 1 / 1)			
Max. input current per MPPT (MPPT1//2/3)	20 A / 20 A / 20 A			
Max. input short circuit current per MPPT (MPPT1/2/3)	25 A / 25 A / 25 A			
AC INPUT & OUTPUT (ON-GRID)				
Rated output power	8 kW	10 kW (AS4777 9999)	12 kW	15 kW (AS4777 9999)
Rated output current	11.6 A	14.5 A	17.4 A	21.8 A
Max. output apparent power	8800 VA	10000 VA (AS4777 9999)	13200 VA	16500 VA
Max. output continuous current	13.4 A	15.2 A	20.0 A	25.0 A
Nominal AC voltage	3 / N / PE, 220 / 380 V 3 / N / PE, 230 / 400 V			
Max. AC input apparent power	16 kVA	20 kVA	20 kVA	20 kVA
Max. AC input current	25.8 A	32.0 A	32.0 A	32.0 A
Nominal AC frequency	50 Hz / 60 Hz			
AC frequency range ^③	50 ± 5 Hz / 60 ± 5 Hz			
Adjustable power factor range	~ 1 (0.8 lagging to 0.8 leading)			
THDi (rated power)	< 3%			
BATTERY				
Battery voltage range	160 ~ 800 V			
Communication interfaces	CAN / RS485			
BMS module	TBMS-MCS0800E			
Battery module	TP-HS50E			
Composition	TBMS-MCS0800E + TP-HS50E x n + Base Dimensions + Series Box (Required for two columns)			
Battery type	Li-ion (LFP)			
Nominal capacity / Nominal capacity ^④	5.1 kWh / 50 Ah			
Usable energy ^⑤	4.6 kWh			
Standard power	3 kW			
Max power	5.1 kW			
Max. charge / discharge current ^⑥	50 A			
Cycle life	> 6000 cycles			
Warranty	10 years			
Safety	CE, RCM, TUV (IEC62619), RoHS, REACH			
TBMS-MCS0800E dimensions (W x H x D) / Weight	730 x 165 x 150 mm / 9.3 kg			
TP-HS50E dimensions (W x H x D) / Weight	730 x 318 x 150 mm / 47 kg			
Base dimensions (W x H x D) / Weight	730 x 75 x 150 mm / 3.9 kg			
Series box dimensions (W x H x D) / Weight	167 x 91.5 x 121 mm / 1.3 kg			

	X3-IES-8K-P	X3-IES-10K-P	X3-IES-12K-P	X3-IES-15K-P
EPS (OFF-GRID) OUTPUT (WITH BATTERY)				
Rated EPS output voltage, frequency	230 V / 400 V, 50 Hz / 60 Hz			
Rated EPS output power	8 kVA	10 kVA	12 kVA	15 kVA
Peak EPS output power	2 times of rated power, 10 s			
Switchover time	< 10 ms			
EFFICIENCY				
Max. efficiency	98.0%			
European efficiency	97.7%			
ENVIRONMENT LIMIT				
Ingress protection	IP66			
Operating ambient temperature range ^⑦	-35 ~ 60°C			
Max. operating altitude	3000 m			
Relative humidity	0 ~ 100% RH (condensing)			
Overvoltage Category	Mains: III, Battery: II, PV: II			
GENERAL				
Dimensions (W x H x D)	717 x 405 x 209.5 mm			
Net weight	40 kg			
Cooling concept	Nature cooling			
Communication interfaces	RS485, Pocket-X, CAN + RS485, DO, DI			
Power consumption (night)	< 40 W for hot standby, < 5 W for cold standby			
Topology	Non-isolated			
Certificates and approvals	IIEC62109-1 / IEC62109-2, VDE 0126-1-1 A1:2012 / VDE-AR-N 4105 / G98 / G99 / AS4777 / EN50549 / CEI 0-21			
AC auxiliary power supply (APS)	Built-in			
PROTECTION				
Protections	Over voltage protection, DC reverse-polarity protection, Residual current detection, Over temperature protection, DC isolation protection, Grid monitoring, DC injection monitoring, Back feed current			
Active anti-islanding method	Frequency shift			
Surge protection (DC / AC)	DC: Type II, AC: Type II			
Arc-fault circuit interrupter (AFCI)	Optional			

① The maximum input voltage is the upper limit of the DC voltage. Any higher input DC voltage would probably damage the inverter

② Input voltage exceeding the MPPT voltage range may trigger inverter protection

③ The AC frequency range may vary from different country codes

④ Test conditions: 25°C, 100% depth of discharge (DoD), 0.2C charge & discharge

⑤ System usable energy may vary with inverter different settings

⑥ Discharge: In case of the battery cell's temperature range of -20°C~10°C and 45°C~53°C, the discharge current will be reduced; Charge: In case of the battery cell's temperature range of 0°C~25°C and 45°C~53°C, the charge current will be reduced. Product charge or discharge power depends on the actual temperature of the battery pack

⑦ Derating above +45°C

All-in-one Residential ESS



X-ESS G4

3-7.5 kW / 5-15 kW
3~12kWh

Smart Management

- Real-time monitoring via SolaX Cloud
- Global MPP scan for optimal energy harvest
- Smart loads management (eg., heat pump, smart EV charger)
- Intelligent ToU-Driven Energy Management

Assured Reliability

- IP65 protection degree
- Support three-phase unbalance output*

High Performance

- 200% PV oversizing and up to 110% AC output
- Max. 16A DC single string input current
- Max. 30A charging/discharging current

Flexible Adaptability

- All-in-one, plug-and-play design
- Quick installation by one person in 30 minutes
- Compatible with EV charger and heat pump

*Only applicable for three-phase model

THE OPTIMAL SOLUTION FOR ENERGY STORAGE

The SolaX X-ESS G4 is an all-in-one smart energy storage system that combines an inverter, battery, and Matebox, streamlining installation for maximum ease and efficiency. The modular design offers flexible configurations, allowing the system to scale according to energy needs.

● X-Hybrid G4

Available in single-phase (3–7.5 kW) and three-phase (5–15 kW) options, the X-Hybrid G4 system supports parallel operation of up to 10 inverters, delivering a maximum power output of 150 kW. It includes integrated fault management and emergency power output, with a rapid switching time of less than 10 ms for uninterrupted power.

● Matebox

The Matebox comes with pre-installed components and cabling, significantly reducing installation time. For enhanced functionality, an advanced X3-Matebox version is available, providing whole-house backup power capabilities.

● Battery T30

The T30 battery is scalable from 3 kWh to 12 kWh, adapting to different energy storage requirements. With built-in temperature control, it operates reliably within a wide temperature range of -30°C to 50°C, ensuring optimal performance in various environmental conditions.

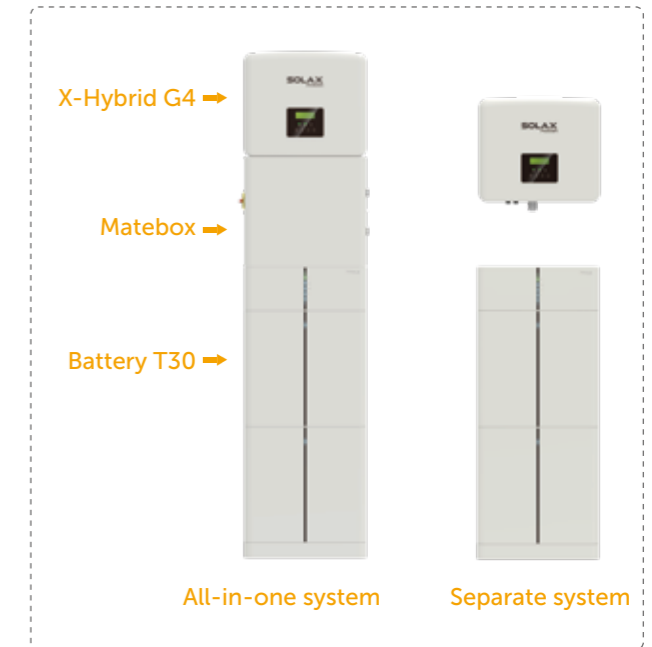

● SolaX Cloud

Real-time Monitoring and Analytics with SolaX Cloud: providing insights to optimize energy consumption and enhance overall system performance.



Battery scalability

